

# PERKO **POWERMATIC**

R100 Controlled Door Closer

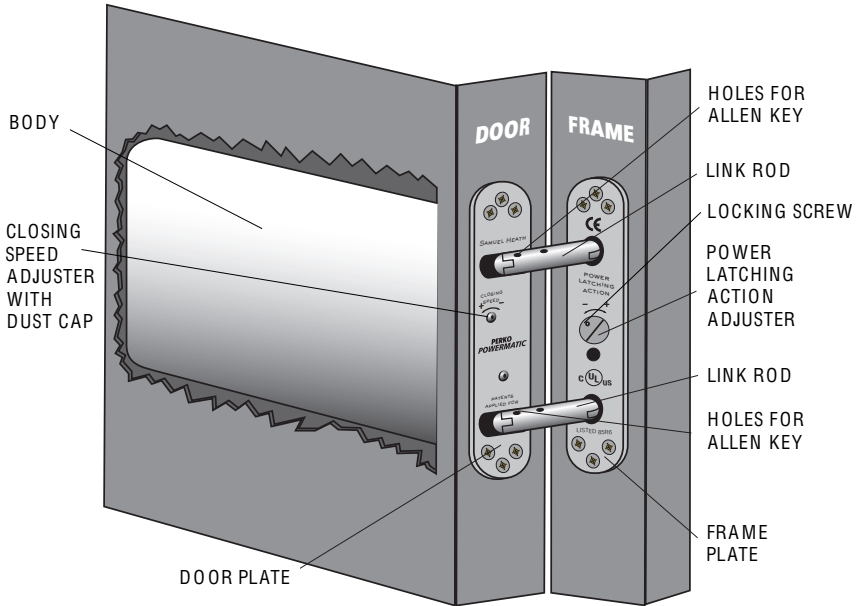

## IMPORTANT NOTICE - FOR FIRE DOOR INSTALLATIONS REFER TO ITEM 1 IN FITTING INSTRUCTIONS





- CE marked and adjustable to conform to power size 3 of Controlled Door Closing Device. BS EN1154: 1997 (Test door 60kg/132lbs).
- UL Approved to UL 10B, UL 10C and UL 228. ADA Compliant. ANSI 156.4 Reg.
- 1 Hour Fire Test BS EN1634-1: 2000.
- Adjustable speed control.
- Adjustable power latching action.
- 1<sup>1</sup>/<sub>2</sub> pairs of hinges should be used in conjunction with this closer on all doors.
- Suitable for doors opening to a maximum of 105°. A door stop should be fitted.
- Maximum door weight 80kg/180lbs, width 950mm/38".
- Suitable for latched and unlatched doors.
- Should **NOT** be used with rising butt hinges, concealed mortice hinges.

**PLEASE READ FITTING INSTRUCTIONS THOROUGHLY  
BEFORE INSTALLATION.**

# PERKO POWERMATIC®

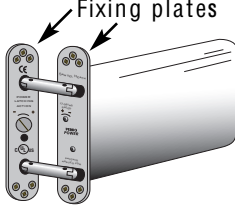
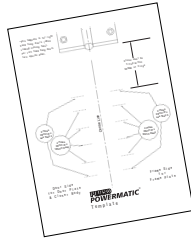
The Third Generation Concealed Door Closer

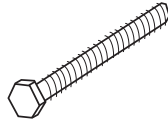
## PARTS LIST

 <p>(A)</p>	 <p>(B)</p>	 <p>(C)</p>
<p>Door Closer - x 1</p>	<p>Template - x 1</p>	<p>Allen Keys - x 2</p>
 <p>(D)</p>	 <p>(E)</p>	 <p>(F)</p>
<p>Screws - x 12</p>	<p>Extractor Bolt - x 1</p>	<p>Allen Key for Adjuster Screw (Locking) x 1</p>

**CHECK ALL COMPONENT PARTS AGAINST PARTS LIST.**

## TOOLS REQUIRED

- Screwdriver (Plain Slotted)
- Screwdriver (Phillips)
- Wood Chisel 25mm x 185mm/1" x 7"
- Solid Centre Auger Bit or Spade Bits 26mm Ø and 28mm Ø 11/16" Ø and 11/8" Ø
- Bradawl
- Power Drill
- Tape Measure
- Pencil
- Adjustable Spanner
- Ruler

*The use of a dedicated morticing tool is highly recommended for multiple installations.*

**Order code R98.XX which includes everything you need.**

**Eye Protectors, Ear Defenders and a Face Mask are recommended during installation of Perko-Powermatic®.**

# 1 IMPORTANT NOTICE

## DOOR CLOSERS FITTED TO A FIRE DOOR.

- Perko Powermatic,<sup>®</sup> conforms to Power Size 3 of Controlled Door Closing Device Standard BS EN1154:1997 when the power latching action is set to maximum.
- Turn adjuster screw fully to positive (+) as explained in 9.
- Closer must be fitted no more than 750mm/30" from floor and within 300mm/12" of a hinge.
- Closer and plates should be bedded in Alfacyrl FR Intumescent Acrylic Mastic available from Samuel Heath.

## 2 TEMPLATE POSITIONING

- Ensure door is plumb, hinges are free, and that timber is sound.
- Take template provided and fold along center line. Open door to 90°.
- Secure template to door edge and frame edge within 300mm/12" of a hinge ensuring the center line is central in line with the pivot point of the hinge.
- Draw a vertical line at the center point of the door edge on the template.

**NB This line must not exceed 35mm/1<sup>3</sup>/<sub>8</sub>" from template centre line.**

**See Fig. 2**

Fig. 1

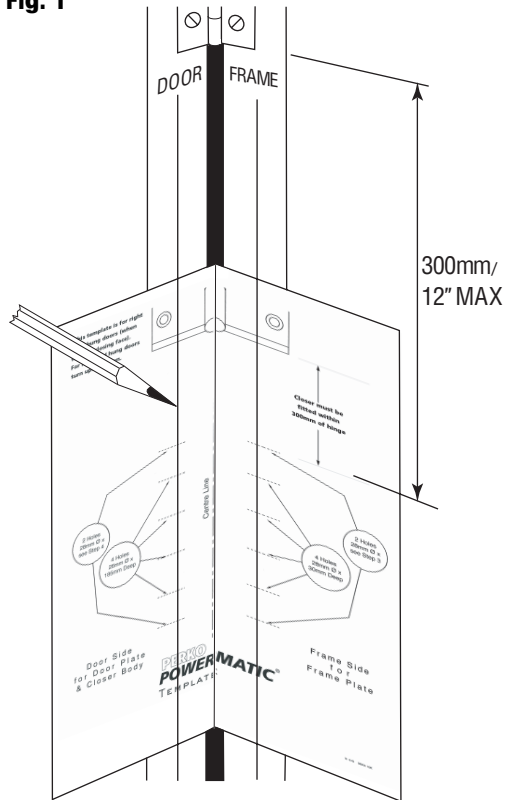

- Repeat this vertical line onto the frame side at the same distance from centre line.
- At each point on the template where the vertical lines cross the horizontal dotted lines mark through the template using a bradawl into the door side edge and frame edge to establish drilling points. Remove template RETAIN FOR REFERENCE.
- Note: Door can now be removed from frame to assist drilling if preferred.

To achieve a maximum opening angle of 105° the centre of the closer must be no more than 35mm/1<sup>3</sup>/<sub>8</sub>" from the pivot point of the hinge.

**Fig. 2**

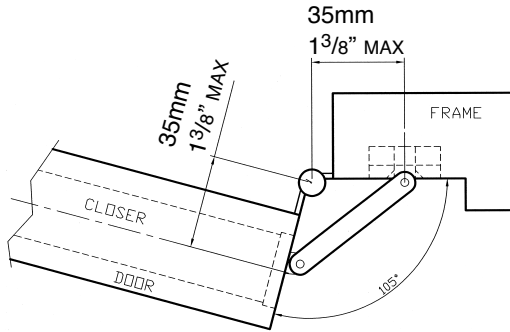

## IMPORTANT

To ensure the 35mm/1<sup>3</sup>/<sub>8</sub>" distance is not exceeded the closer and fixing plate can both be offset in the door leaf and jamb (closer to the hinge pivot point) by up to a maximum of 6mm/1/4" as illustrated below.

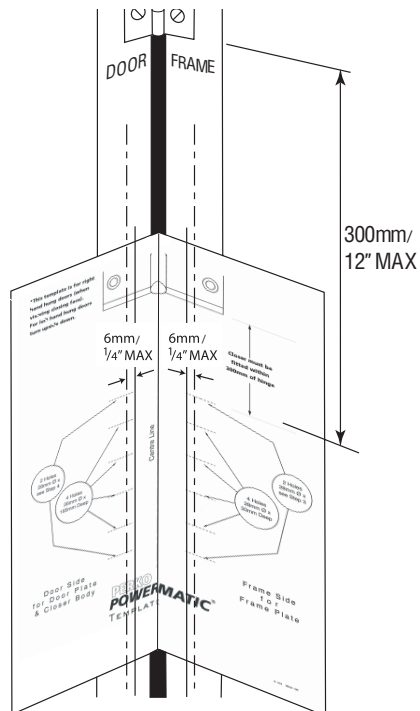

### 3 FRAME PREPARATION FOR FRAME PLATE

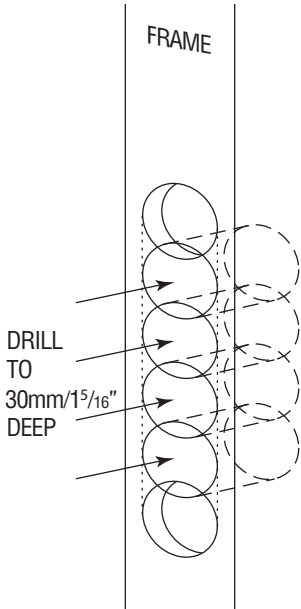

**NB** To ensure correct operation of closer there must be a 3mm/1/8" gap between the two fixing plates when the door is in the closed position. These instructions are based on the gap between door and frame being 3mm ± 1.0mm.

- Drill 4 x 28mm/1 1/8" Ø holes x30mm/1 5/16" deep to accept frame plate assembly as indicated on template.
- Drill 2 x 28mm/1 1/8" Ø holes x5mm deep to accept frame plate ends.
- Remove excess timber between drilled holes to accommodate frame plate.

### 4 DOOR PREPARATION FOR BODY & DOOR PLATE

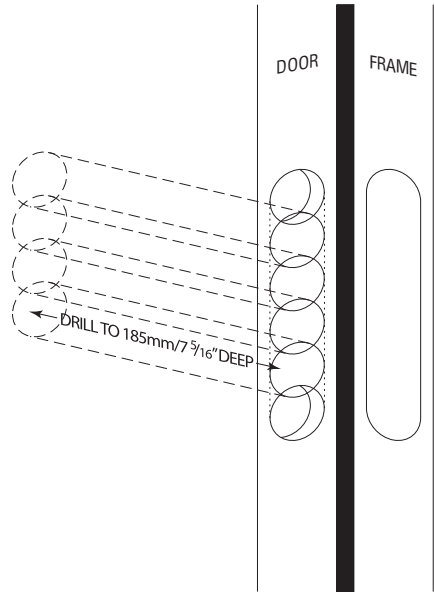

- Drill 4 x 26mm/1 1/16" Ø x 185mm/7 5/16" deep holes to accept closer body as indicated on the template.
- Drill 2 x 28mm/1 1/8" Ø holes x5mm to accept door plate ends.
- Remove excess timber between drilled holes to accept the closer body and door plate.

# 5 INSTALLING CLOSER

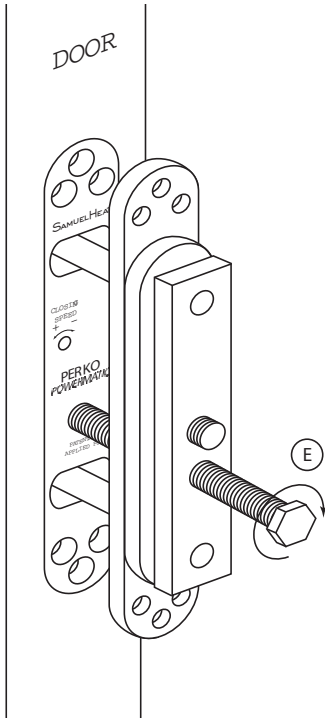

- Insert closer body into door.
- Insert extractor bolt (E) into position and rotate clockwise until holes in link rods appear.
- Generally for thicker doors expose both holes on each rod.

# 6

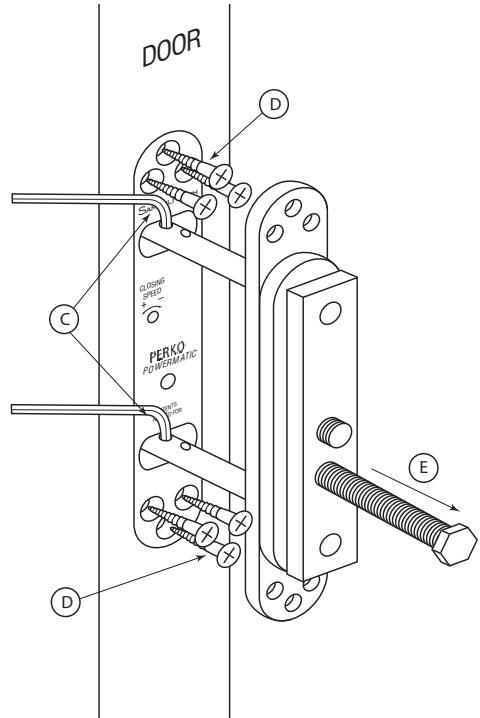

- Insert the allen keys (C) through both top and bottom link rod holes.

**Both allen keys must be correctly located.**

- Remove extractor bolt.
- Secure door plate to door with six screws (D).

## IMPORTANT

**With composite doors and door linings it is essential to drill pilot holes  $\text{\O} \frac{3}{32}$ " (2.5mm) to suit fixing screws.**

# 7

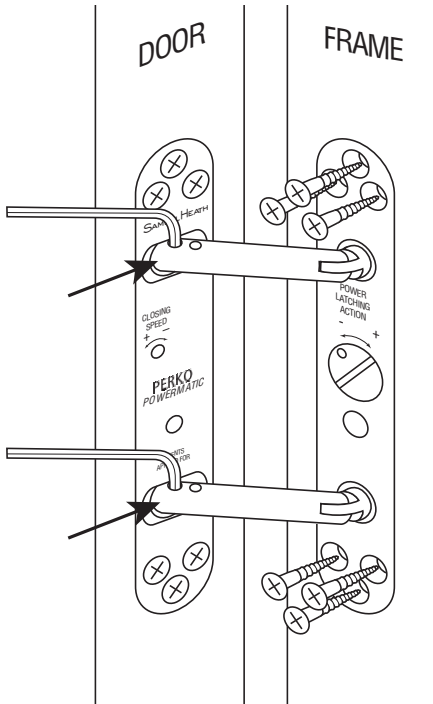

- With the closer secure and now held open by allen keys, if necessary firmly push both link rods across door plate and offer frame plate into frame void. Secure with six screws (D).
- Open door slightly and remove allen keys.
- Installation is now complete.

# 8 ADJUSTMENT - CLOSING SPEED

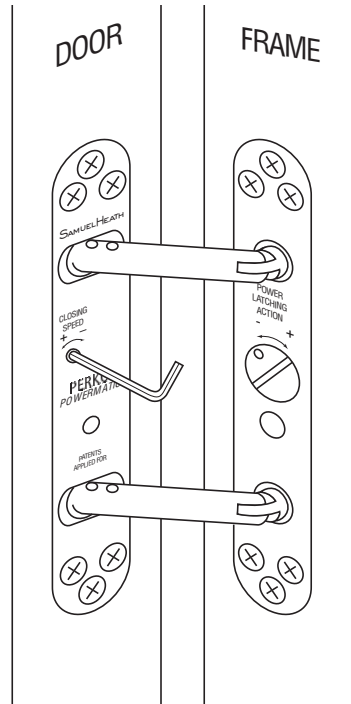

- Remove dust cap.
- Use one of the allen keys (C) to adjust closing speed.
- Positive (+) increases door speed. Negative (-) reduces door speed, as indicated on door plate.

# 9 ADJUSTMENT - POWER LATCHING ACTION

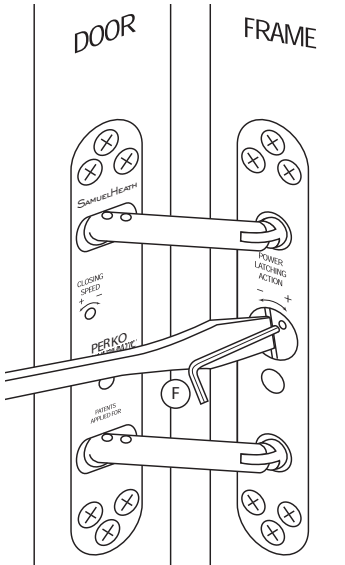

- The power latching action can be adjusted using a plain flat ended screwdriver.
- Loosen locking screw using allen key (F) to allow the adjuster screw to turn.
- Positive (+) increases the angle at which latching action engages. Negative (-) decreases angle at which the latching action engages.
- Re-tighten locking screw when correct power latching action achieved.

The Perkopower is protected by the following Patents and Applications.

<b>CANADA</b>	2365822 2436363
<b>HONG KONG</b>	1038953
<b>JAPAN</b>	2000-602490
<b>SINGAPORE</b>	82862
<b>TAIWAN</b>	156554
<b>USA</b>	6625847 2004/0111831
<b>UK</b>	GB25447175 GB2415014 EP1605126

**AUSTRIA**

**BELGIUM**

**DENMARK**

**FRANCE**

**GERMANY**

**IRELAND**

EP1605126

**ITALY**

**LUXEMBOURG**

**NETHERLANDS**

**SPAIN**

**SWEDEN**

**SWITZERLAND**

**LIECHTENSTEIN**



\*This template is for right hand hung doors (when viewing closing face).  
For left hand hung doors turn upside down.

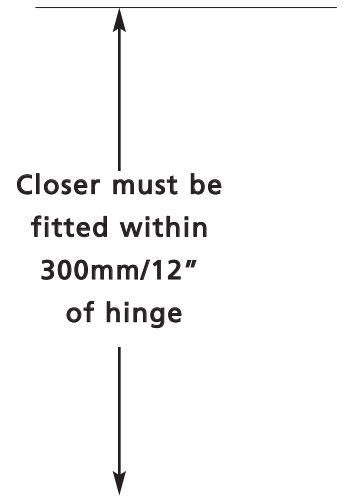
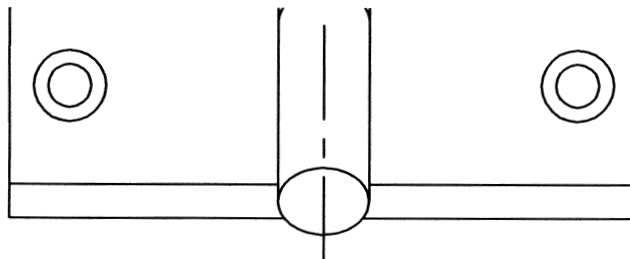

Closer must be fitted within 300mm/12" of hinge

35mm MAX

Centre Line

2 Holes  
28mm/1 1/8" Ø  
x see Step 4

4 Holes  
26mm/1 1/16" Ø  
x 185mm/  
7 5/16" Deep

DOOR SIDE  
FOR DOOR PLATE  
& CLOSER BODY

2 Holes  
28mm/1 1/8" Ø x  
see Step 3

4 Holes  
28mm/1 1/8" Ø  
x 30mm Deep

FRAME SIDE  
FOR  
FRAME PLATE

**PERKO**  
**POWERMATIC**<sup>®</sup>  
TEMPLATE